

Original Article

Optimized Hybrid Ac/Dc Microgrid System for Enhanced Energy Reliability and Sustainability

Ms. Kowshika R¹, Suthana Raja Rexlin G².

^{1,2}Department of Electrical and Electronics Engineering, Grace College Of Engineering, Mullakkadu, Thoothukudi.

Abstract: The development and optimization of a hybrid micro grid system integrating solar photovoltaic (PV), wind turbine, and diesel engine generators to create a reliable and sustainable energy solution. The micro grid is designed to operate with both AC (Alternating Current) and DC (Direct Current) components to maximize efficiency and flexibility in energy distribution and usage. Renewable energy sources – solar and wind – while ensuring a continuous power supply through a diesel generator as a backup during periods of low renewable energy availability. The system's architecture includes AC and DC buses, converters, inverters, and controllers to manage the power flow between different energy sources and loads effectively.

Keywords: Hybrid Microgrid, Ac/Dc Integration, Energy Reliability, Sustainable Energy Systems, Microgrid Optimization, Renewable Energy Sources, Energy Storage Solutions, Power Distribution Efficiency, Grid Resilience, Smart Grid Technology.

INTRODUCTION

General information regarding microgrid As electric distribution technology steps into the next century, many trends are becoming noticeable that will change the requirements of energy delivery. These modifications are being driven from both the demand side where higher energy availability and efficiency are desired and from the supply side where the integration of distributed generation and peaks having technologies must be accommodated. Microgrid power system 2 Power systems currently undergo considerable change in operating requirements mainly as a result of deregulation and due to an increasing amount of distributed energy resources (DER). In many cases DERs include different technologies that allow generation in small scale (microsources) and some of them take advantage of renewable energy resources (RES) such as solar, wind or hydro energy. Having microsources close to the load has the advantage of reducing transmission losses as well as preventing network congestions. Moreover, the possibility of having a power supply interruption of end-customers connected to a low voltage (LV) distribution grid (in Europe 230 V and in the USA 110 V) is diminished since adjacent microsources, controllable loads and energy storage systems can operate in the islanded mode in case of severe system disturbances.

This is identified nowadays as a microgrid. A typical microgrid. The energy storage systems usually include batteries and flywheels. The storing device in the microgrid is equivalent to the rotating reserve of large generators in the conventional grid which ensures the balance between energy generation and consumption especially during rapid changes in load or generation. From the customer point of view, microgrids deliver both thermal and electricity requirements and in addition improve local reliability, reduce emissions, improve power excellence by supportive voltage and reducing voltage dips and potentially lower costs of energy supply. From the utility viewpoint, application of distributed energy sources can potentially reduce the demand for distribution and transmission facilities. Clearly, distributed generation located close to loads will reduce flows in transmission and distribution circuits with two important effects: loss reduction and ability to potentially substitute for network assets. In addition, the presence of generation close to demand could increase service quality seen by end customers.



Microgrids can offer network support during the time of stress by relieving congestions and aiding restoration after faults. The development of microgrids can contribute to the reduction of emissions and the mitigation of climate changes. Technical challenges linked with the operation and controls of microgrids are immense. Ensuring stable operation during network disturbances, maintaining stability and power quality in the islanding mode of operation necessitates the improvement of sophisticated control strategies for microgrid's inverters in order to provide stable frequency and voltage in the presence of arbitrarily varying loads. In light of these, the microgrid concept has stimulated many researchers and attracted the attention of governmental organizations in Europe, USA and Japan. Nevertheless, there are various technical issues associated with the integration and operation of microgrids.

SYSTEM IMPLEMENTATION

2.1 Existing System:

In the existing system, power generation is often dominated by diesel generators, which provide a stable but environmentally harmful and costly energy source. Solar and wind energy are typically used as supplementary sources, but their intermittent nature poses challenges. AC loads are usually directly powered by these generators, while DC loads might have dedicated power supplies or use converters to step down the AC power. Energy storage, if present, is often minimal, resulting in an overreliance on diesel generators during periods of low renewable energy generation.

Drawbacks:

1. High operational costs due to diesel fuel consumption.
2. Environmental pollution from diesel engine emissions.
3. Underutilization of renewable energy potential.
4. Limited energy storage leading to inefficient energy management.

2.2 Proposed System:

The proposed hybrid microgrid system aims to enhance efficiency, sustainability, and reliability by optimizing the use of solar and wind energy, incorporating advanced energy storage solutions, and ensuring seamless integration of AC and DC loads. Solar panels and wind turbines will be the primary energy sources, supported by a diesel generator as a backup for periods of low renewable generation. Advanced battery storage systems will store excess renewable energy for use during periods of high demand or low generation.

Key Features:

1. **Enhanced Renewable Integration:** Solar and wind power will be the primary energy sources, significantly reducing reliance on diesel generators.
2. **Advanced Energy Storage:** Efficient battery systems will store excess renewable energy, ensuring a stable energy supply even when renewable generation is low.
3. **Smart Energy Management:** An intelligent energy management system will optimize the use of different power sources based on availability and demand, enhancing overall system efficiency.
4. **Dual Load Handling:** Both AC and DC loads will be managed seamlessly, with converters ensuring efficient power distribution and utilization.
5. **Environmental and Economic Benefits:** Reduced diesel consumption will lower operational costs and environmental impact, promoting a greener and more sustainable energy solution.

Advantages:

1. **Cost Efficiency:** Reduced fuel costs and lower maintenance requirements for diesel generators.
2. **Environmental Impact:** Lower emissions and a smaller carbon footprint.
3. **Reliability:** Improved energy reliability through diversified energy sources and robust storage solutions.
4. **Scalability:** The system can be easily scaled up or down based on energy demand and resource availability.

2.3 Block Diagram:

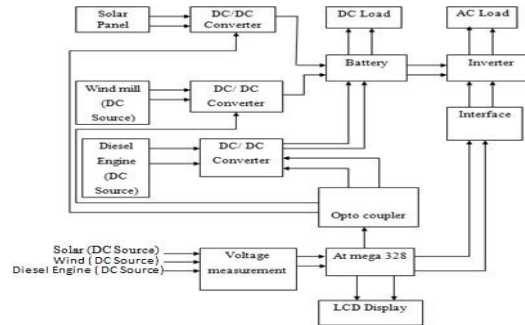

Figure 2.1: Proposed Block Diagram

2.3.1 Block Diagram Description:

Solar Panel

- Converts sunlight into DC electrical energy.

DC/DC Converter (Solar Panel)

- Regulates the DC output from the solar panel to a suitable level for charging the battery and supplying the system.

Wind Mill

- Converts wind energy into DC electrical energy.

DC/DC Converter (Wind Mill)

- Regulates the DC output from the wind mill to a suitable level for charging the battery and supplying the system.

Hybrid System

- Combines the power from the solar panel and wind mill, ensuring efficient energy use and stability.

DC/DC Converter (Hybrid System)

- Further regulates the combined DC output from the hybrid system to ensure a consistent and suitable voltage for the battery and the rest of the system.

Opto Coupler

- Provides electrical isolation between different parts of the system, protecting sensitive components like the microcontroller (ATmega 328) from high voltages.

ATmega 328 (Microcontroller)

- Central control unit that manages the operation of the battery management system, including monitoring, control, and communication.

Voltage Measurement

- Measures the voltage levels of various parts of the system (e.g., battery, DC outputs) and provides feedback to the microcontroller for monitoring and control.

LCD Display

- Displays system parameters and status information, such as voltage levels, charge status, and load conditions, for user monitoring.

Interface

- Allows user interaction with the system, possibly including buttons or a touch interface for configuring settings and viewing information.

Inverter

- Converts DC electrical energy from the battery to AC electrical energy for AC loads.

AC Load

- Devices and appliances that operate on AC power supplied by the inverter.

DC Load

- Devices and appliances that operate on DC power directly from the system.

Battery

- Stores electrical energy generated by the solar panel and wind mill, and supplies power to the system when generation is insufficient.

2.4 Circuit Diagram:

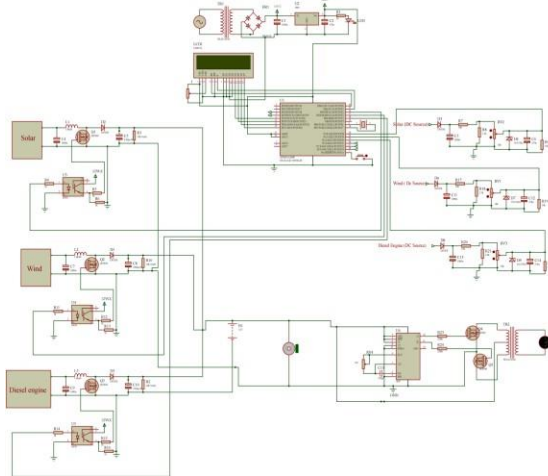

Figure 2.2: Proposed Circuit Diagram

2.4.1 Circuit Diagram Description:

Solar Panel and Wind Mill generate DC power. Each has its own DC/DC Converter to regulate voltage. Outputs from these converters are fed into the Hybrid System. Combines the energy from both sources. Passes the combined energy through another DC/DC Converter for further regulation. The regulated DC power charges the battery. The battery is connected to the Inverter for AC power generation and directly to DC loads. Voltage Measurement units are placed at key points (e.g., battery terminals) to monitor system voltages. Opto Couplers provide isolation and protection for the microcontroller (ATmega 328).The microcontroller processes the data, controls charging/discharging, and interfaces with the LCD Display for user information. The user interface allows interaction with the system. The Inverter converts battery DC power to AC for AC loads. DC loads are powered directly from the battery or hybrid system.

HARDWARE DETAILS

3.1 DC to DC Boost Converter:

The low input DC voltage is converted into high output DC voltage using DC to DC boost converter. As the input voltage is stepped up compared to output voltage, hence, it is also called as a step up converter. Generally, DC to DC converters can be designed using power semiconductor switching devices and discrete electrical and electronics components.

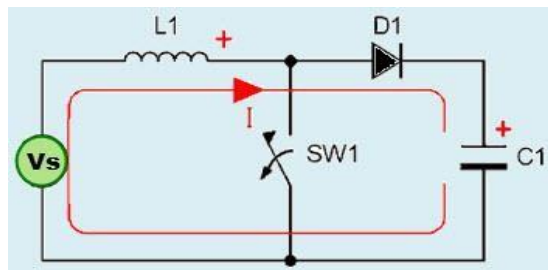

Figure. 3.1 DC to DC Boost Converter Continuous Conduction Mode Circuit

The continuous conduction mode circuit of the DC to DC boost converter is shown in the figure that consists of an inductor, capacitor, switching device, diode, and input voltage source. This boost converter

circuit switch is controlled using a pulse width modulator (PWM). If this switch is in ON state, then energy will be developed in the inductor and thus more energy will be delivered to the output.

3.2 Opto Coupler:

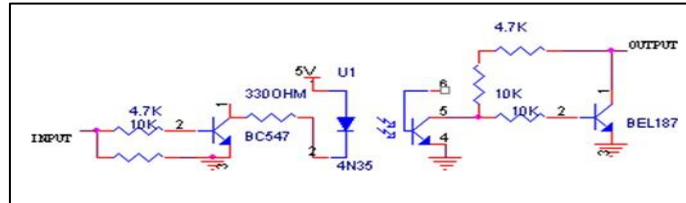

Figure 3.2 Optocoupler Circuit

In electronics, an **opto-isolator**, also called an **optocoupler**, **photocoupler**, or **optical isolator**, is "an electronic device designed to transfer electrical signals by utilizing light waves to provide coupling with electrical isolation between its input and output". The main purpose of an opto-isolator is "to prevent high voltages or rapidly changing voltages on one side of the circuit from damaging components or distorting transmissions on the other side." Commercially available opto-isolators withstand input-to-output voltages up to 10 kV and voltage transients with speeds up to 10 kV/μs.

3.3 ATMEGA-328 IC:

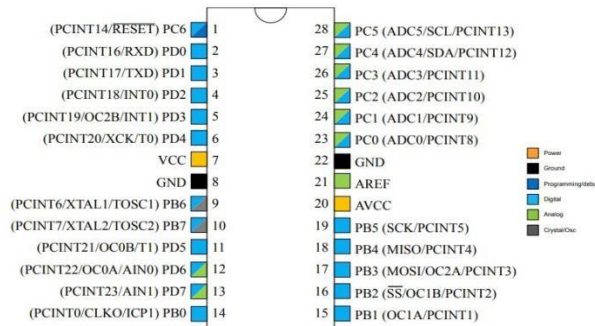

Figure. 3.3 ATMEGA-328 PIN Diagram

This ATMEGA-328 integrated chip consists of 28 pins. It consists of 6 analog inputs that are shown in the pin diagram. Analog inputs can be represented as PC0 to PC5. These analog input pins possess the continuous time signal which acts as an analog input for the system. Further it also consists of 12 digital inputs. It can be represented as PD1 to PD11 which act as a digital input ports based on pulse width modulation (PWM). These PWM, which transmits the signal in the form of discredited form. Both analog and digital input ports can be used for various applications for the input power supply, VCC and GND pins are used. Pins PB6 and PB7, which acts as a crystal to generate a clock signal. By using these crystal, we can generate the clock signals and by these clock signals, we can use this clock signals for input sources. PC6 pin are the one where it can be used for the reset option. Resetting the program can be done by using this PC6 pin.

3.4 LCD Display:



Figure 3.4 LCD Display

Liquid Crystal Displays (LCDs) have materials, which combine the properties of both liquid and crystals. Rather than having a melting point, they have a temperature range within which the molecules are almost as mobile as they would be in a liquid, but are grouped together in an ordered form similar to a

consists of two glass panels, with the liquid crystal material sandwiched in between them. The inner surface of the glass plates are coated with transparent electrodes which define the character, symbols or patterns to be displayed. Polymeric layers are present in between the electrodes and the liquid crystal, which makes the liquid crystal molecules to maintain a defined orientation angle. On each polarizer are pasted outside the two glass panels. This polarizer would rotate the light rays passing through them to a definite angle, in a particular direction.

3.5 Voltage Measuring Circuit:

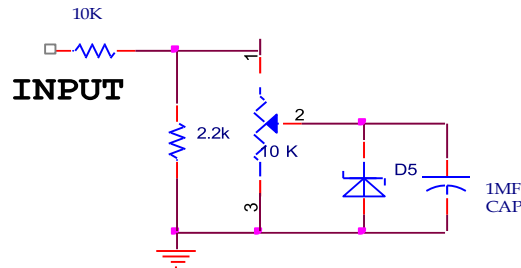

Figure 3.5 Measurement circuit DC voltage

The attenuator circuit reduces the voltage to a required level. The attenuator circuit usually consists of passive devices made from simple voltage divider networks. Switching between different resistances forms adjustable stepped attenuators and continuously adjustable ones using potentiometers. A capacitor is connected across the rectifier to filter out the ripples. Then the filtered output is given to the micro controller.

3.6 Battery:

Lead-acid batteries are the oldest type of rechargeable battery. Despite having a very low energy-to-weight ratio and a low energy-to-volume ratio, their ability to supply high surge currents means that the cells maintain a relatively large power-to-weight ratio. These features, along with their low cost, make them attractive for use to provide the high current.



Figure 3.6 Battery 6V

3.7 Solar Panel:

A solar panel (also solar module, photovoltaic module or photovoltaic panel) is a packaged, connected assembly of solar cells, also known as photovoltaic cells. The solar panel can be used as a component of a larger photovoltaic system to generate and supply electricity in commercial and residential applications.

Because a single solar panel can produce only a limited amount of power, many installations contain several panels. A photovoltaic system typically includes an array of solar panels, an inverter, and sometimes a battery and interconnection wiring.



Figure 3.7 Solar panel

RESULT & DISCUSSION

4.1 Working Principle:

The development and optimization of a hybrid micro grid system integrating solar photovoltaic (PV), wind turbine, and diesel engine generators aim to create a reliable and sustainable energy solution. This micro grid is designed to operate with both AC (Alternating Current) and DC (Direct Current) components to maximize efficiency and flexibility in energy distribution and usage. The renewable energy sources, solar and wind, are supplemented by a diesel generator to ensure a continuous power supply during periods of low renewable energy availability. The system's architecture includes AC and DC buses, converters, inverters, and controllers to manage power flow effectively between different energy sources and loads.

The hardware model implements a 12V DC system and a 230V AC system, supporting a 1-watt AC load and a 12V DC load, such as a DC motor. Key components include a 9V, 5-watt solar panel, a windmill, a diesel generator, an Atmega328 microcontroller, an LCD display for monitoring input voltage, a voltage measurement circuit, a DC-DC converter to boost voltage to charge a 12V battery, an inverter for AC loads, and PWM control to manage power output. The system operates by generating DC power from the solar panel and windmill, while the diesel generator provides backup power. The DC-DC converter boosts voltage to ensure stable energy storage in the battery. Energy distribution is managed through AC and DC buses, converters, inverters, and controllers, ensuring effective power flow. The Atmega328 microcontroller monitors input voltage via the voltage measurement circuit and displays it on the LCD. When the input voltage exceeds 6V, the PWM control adjusts the power output to maintain system stability. The inverter converts DC to AC power for the 230V AC load, while the DC power directly supplies the 12V DC load, such as a DC motor. This hardware model demonstrates the feasibility and functionality of the hybrid microgrid system, showcasing its potential for reliable and sustainable energy distribution in practical applications.

4.2 Result:

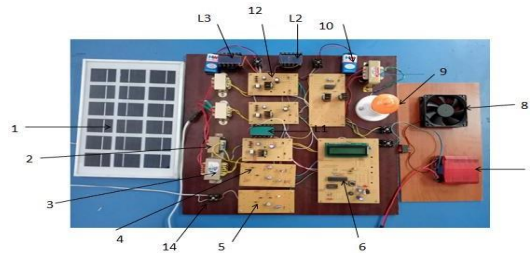

Figure 4.1: Hardware prototype model "Hybrid Micro Grid"

The above figure 4.1 is show known we are used some electronics components for following

1. Solar Panel (9V/5Watts)
2. Isolation Transformer (0-12V/300mA)
3. Power supply Transformer (0-12/1Amps)
4. DC Voltage Measurement
5. Solar Voltage Measurement
6. Microcontroller (Atmega328)
7. Battery (12V)

8. DC Load 12V Fan
9. AC Load
10. Diesel Power Source (9V)
11. Windmill Power Source (9V)
12. DC-DC Boost Converter
13. L1, L2, L3 -Inductor

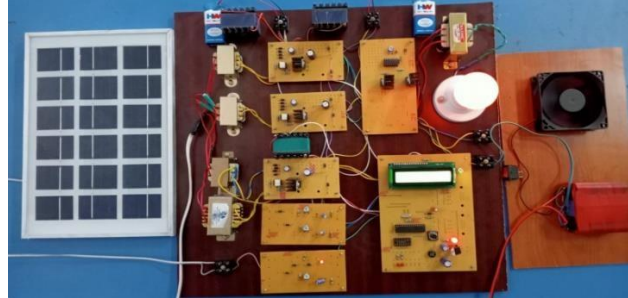

Figure 4.2: Power ON Hardware Model

The figure 4.2 is shown an power ON the hardware model. The hardware model to monitoring the solar voltage, wind voltage (9V battery), Diesel voltage (9V battery) to using LCD display to help of Microcontroller Atmega328. The input for every power source above 6V the controller output PWM.

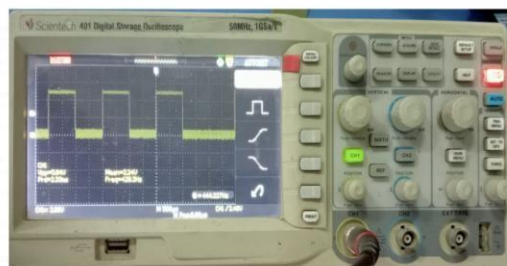

Figure 4.3: PWM pulse Output

Figure 4.3 shows the PWM output for the Atmega328 microcontroller on pins 10, 12, and 3. The PWM pulse has a frequency of 5 kHz and an amplitude of 5V. The duty cycle ranges from 0% to 100%.



Figure 4.4: Hardware Display for SV



Figure 4.5: Charging Voltage Solar Energy

The above figure 4.4 and 4.5 shows solar input voltage is 8V to display the LCD. The solar voltage above 6V PWM pulse control through DC-DC converter output voltage to increase the 13.4V DC for 12V battery charging voltage.



Figure 4.6: Hardware Display for WV

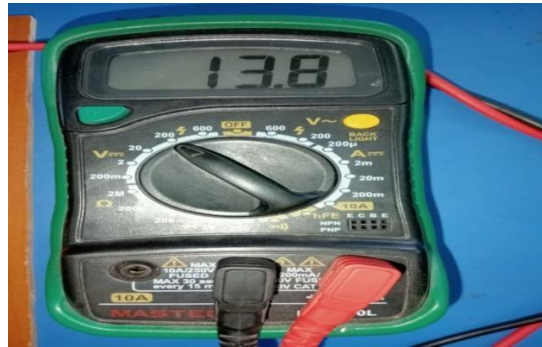

Figure 4.7: Charging Voltage Wind energy

The above figure 4.6 and 4.7 shows wind generator for prototype voltage for (9V battery) input voltage is 9.38V to display the LCD. The wind voltage above 6V PWM pulse control through DC-DC converter output voltage to increase the 13.8V DC for 12V battery charging voltage.



Figure 4.8: Hardware Display for WV

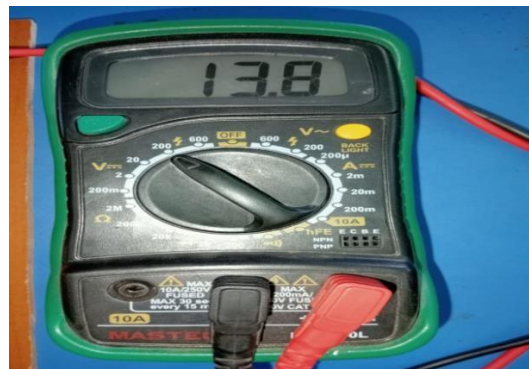

Figure 4.9: Charging Voltage Wind energy

The above figure 5.8 and 5.9 shows Diesel generator for prototype voltage for (9V battery) input voltage is 9.34V to display the LCD. The diesel generator voltage above 6V PWM pulse control through DC-DC converter output voltage to increase the 13.8V DC for 12V battery charging voltage.

CONCLUSION

The hardware model of the hybrid micro grid system demonstrates the integration of solar photovoltaic (PV), wind turbine, and diesel engine generators to provide a reliable and sustainable energy solution. The system is designed to operate with both AC (Alternating Current) and DC (Direct Current) components, enhancing efficiency and flexibility in energy distribution and usage. The renewable energy sources – solar and wind – are supplemented by a diesel generator, ensuring a continuous power supply during periods of low renewable energy availability. The system architecture includes AC and DC buses, converters, inverters, and controllers to manage power flow effectively between different energy sources and loads. In this hardware model, we implemented a 12V DC system and a 230V AC system, supporting a 1-watt AC load and a 12V DC load, such as a DC motor. This configuration successfully demonstrates the feasibility and functionality of the hybrid micro grid system, showcasing its potential for reliable and sustainable energy distribution in practical applications.

REFERENCES

- [1] Tortorella G.L., Fogliatto F.S., Cauchick-Miguel P.A., Kurnia, S. and Jurburg, D. Integration of industry 4.0 technologies into total productive maintenance practices.
- [2] Baek S.Y., Kim, Y.S., Kim, W.S., Baek S.M. and Kim, Y.J. Development and verification of a simulation model for a 120-kW class electric AWD (all-wheel-drive) tractor during driving operation
- [3] Berecibar M., Garmendia M., Gandiaga I., Crego J. and Villarreal I. State of health estimation algorithm of LiFePO₄ battery packs based on differential voltage curves for battery management system application.
- [4] Cipollone R., Di Battista D., Marchionni M. and Villante C. Model-based design and optimization of a fuel cell electric vehicle.
- [5] Coronado C.R., de Carvalho Jr. A., Yoshioka J.T. and Silveira J.L. Determination of ecological efficiency in internal combustion engines, The use of biodiesel. Appl.
- [6] Costa C.M., Barbosa J.C., Castro H., Gonçalves R. and Lanceros-Méndez, S. Electric vehicles To what extent are environmentally friendly and cost-effective- Comparative work by European countries.
- [7] Chanthati, Sasibhushan Rao. (2021). How the Power of Machine - Machine Learning, Data Science and NLP Can Be Used to Prevent Spoofing and Reduce Financial Risks. 10.13140/RG.2.2.18761.76640.
- [8] Del Pero F., Delogu M. and Pierini M. Life Cycle Assessment in the automotive sector A comparative casework of Internal Combustion Engine (ICE) and electric car. Procedia Struct.
- [9] Naga Ramesh Palakurti, 2023. "Evolving Drug Discovery: Artificial Intelligence and Machine Learning's Impact in Pharmaceutical Research" *ESP Journal of Engineering & Technology Advancements* 3(3): 136-147. [Link]
- [10] Naga Ramesh Palakurti, 2022. "AI Applications in Food Safety and Quality Control" *ESP Journal of Engineering & Technology Advancements* 2(3): 48-61. [Link]
- [11] Chanthati, S. R. (2024). An automated process in building organic branding opportunity, budget Intensity, recommendation in seasons with Google trends data. Sasibhushan Rao Chanthati. <https://doi.org/10.30574/wjaets.2024.12.2.0326>
- [12] Kumar Shukla, Nimeshkumar Patel, Hirenkumar Mistry, 2024. "Securing The Cloud: Strategies and Innovations In Network Security For Modern Computing Environments" Volume 11, Issue 04 pp. 1786-1796. [Link]
- [13] Muthukumaran Vaithianathan, Mahesh Patil, Shunyee Frank Ng, Shiv Udgar, 2024. "Verification of Low-Power Semiconductor Designs Using UVM", *ESP Journal of Engineering & Technology Advancements* 4(3): 28-44.
- [14] Doctor, A., B. Vondenbusch, and J. Kozak. "Bone segmentation applying rigid bone position and triple shadow check method based on RF data." *Acta of Bioengineering and Biomechanics*, 13.2 (2011): 3-11.
- [15] Jaseem Pookandy, Enhancing Customer Relationship Management with Salesforce: A Comprehensive Review, *International Journal of Computer Engineering and Technology (IJCET)*, 15(4), 2024, pp. 64-84
- [16] Muthukumaran Vaithianathan, Mahesh Patil, Shunyee Frank Ng, Shiv Udgar, 2024. "Energy-Efficient FPGA Design for Wearable and Implantable Devices" *ESP International Journal of Advancements in Science & Technology (ESP-IJAST)* Volume 2, Issue 2: 37-51.

- [19] Jacopo Pianigiani, Michal Styszynski, Atul S Moghe, Joseph Williams, Sahana Sekhar Palagrahara Chandrashekar, Tong Jiang, Rishabh Ramakant Tulsian, Manish Krishnan, Soumil Ramesh Kulkarni, Vinod Nair, Jeba Paulaiyan, Sukhdev S. Kapur, Ashok Ganesan, 2020. *Automation of Maintenance Mode Operations for Network Devices*, US10742501B1. [Link]
- [20] Chandrakanth Lekkala, "Utilizing Cloud - Based Data Warehouses for Advanced Analytics: A Comparative Study", *International Journal of Science and Research (IJSR)*, Volume 11 Issue 1, January 2022, pp. 1639-1643, <https://www.ijsr.net/getabstract.php?paperid=SR24628182046>
- [21] Julian, Anitha , Mary, Gerardine Immaculate , Selvi, S. , Rele, Mayur & Vaithianathan, Muthukumaran (2024) Blockchain based solutions for privacy-preserving authentication and authorization in networks, *Journal of Discrete Mathematical Sciences and Cryptography*, 27:2-B, 797-808, DOI: [10.47974/IJDMSC-1956](https://doi.org/10.47974/IJDMSC-1956)
- [22] Muthukumaran Vaithianathan, 2024. "Digital Signal Processing for Noise Suppression in Voice Signals", *IJCSPUB - INTERNATIONAL JOURNAL OF CURRENT SCIENCE* (www.IJCSPUB.org), ISSN: 2250-1770, Vol.14, Issue 2, page no.72-80, April-2024, Available: <https://rjpn.org/IJCSPUB/papers/IJCSP24B1010.pdf>
- [23] Muthukumaran Vaithianathan, "Real-Time Object Detection and Recognition in FPGA-Based Autonomous Driving Systems," *International Journal of Computer Trends and Technology*, vol. 72, no. 4, pp. 145-152, 2024. Crossref, <https://doi.org/10.14445/22312803/IJCTT-V72I4P119>
- [24] Muthukumaran Vaithianathan, Mahesh Patil, Shunyee Frank Ng, Shiv Udgar, 2023. "Comparative Study of FPGA and GPU for High-Performance Computing and AI" *ESP International Journal of Advancements in Computational Technology (ESP-IJACT)* Volume 1, Issue 1: 37-46. [PDF]
- [25] Muthukumaran Vaithianathan, Mahesh Patil, Shunyee Frank Ng, Shiv Udgar, 2024. "Low-Power FPGA Design Techniques for Next-Generation Mobile Devices" *ESP International Journal of Advancements in Computational Technology (ESP-IJACT)* Volume 2, Issue 2: 82-93. [PDF]
- [26] Dhamotharan Seenivasan, Muthukumaran Vaithianathan, 2023. "Real-Time Adaptation: Change Data Capture in Modern Computer Architecture" *ESP International Journal of Advancements in Computational Technology (ESP-IJACT)* Volume 1, Issue 2: 49-61. [PDF]
- [27] Muthukumaran Vaithianathan, Mahesh Patil, Shunyee Frank Ng, Shiv Udgar, 2024. "Integrating AI and Machine Learning with UVM in Semiconductor Design" *ESP International Journal of Advancements in Computational Technology (ESP-IJACT)* Volume 2, Issue 3: 37-51. [PDF]
- [28] Chanthathi, Sasibhushan Rao. (2021). *A segmented approach to encouragement of entrepreneurship using data science*. *World Journal of Advanced Engineering Technology and Sciences*. <https://doi.org/10.30574/wjaets.2024.12.2.0330>, [link]
- [29] Patel, N. (2024, March). SECURE ACCESS SERVICE EDGE(SASE): "EVALUATING THE IMPACT OF CONVERGED NETWORK SECURITY ARCHITECTURES IN CLOUD COMPUTING." *Journal of Emerging Technologies and Innovative Research*. <https://www.jetir.org/papers/JETIR2403481.pdf>
- [30] Vishwanath Gojanur , Aparna Bhat, "Wireless Personal Health Monitoring System", *IJETCAS:International Journal of Emerging Technologies in Computational and Applied Sciences*, eISSN: 2279-0055, pISSN: 2279-0047, 2014. [Link]
- [31] Mistry, H., Shukla, K., & Patel, N. (2024). Transforming Incident Responses, Automating Security Measures, and Revolutionizing Defence Strategies through AI-Powered Cybersecurity. *Journal of Emerging Technologies and Innovative Research*, 11(3), 25. <https://www.jetir.org/>
- [32] Aparna Bhat, "Comparison of Clustering Algorithms and Clustering Protocols in Heterogeneous Wireless Sensor Networks: A Survey," 2014 *INTERNATIONAL JOURNAL OF SCIENTIFIC PROGRESS AND RESEARCH (IJSPR)*-ISSN : 2349-4689 Volume 04- NO.1, 2014. [Link]
- [33] Shashikant Tank Kumar Mahendrabhai Shukla, Nimeshkumar Patel, Veeral Patel, 2024." AI BASED CYBER SECURITY DATA ANALYTIC DEVICE", 414425-001, [Link]
- [34] Aparna Bhat, Rajeshwari Hegde, "Comprehensive Study of Renewable Energy Resources and Present Scenario in India," 2015 *IEEE International Conference on Engineering and Technology (ICETECH)*, Coimbatore, TN, India, 2015. [Link]
- [35] Sarangkumar Radadia Kumar Mahendrabhai Shukla ,Nimeshkumar Patel ,Hirenkumar Mistry,Keyur Dodiya 2024." CYBER SECURITY DETECTING AND ALERTING DEVICE", 412409-001, [Link]
- [36] Aparna K Bhat, Rajeshwari Hegde, 2014. "Comprehensive Analysis Of Acoustic Echo Cancellation Algorithms On DSP Processor", *International Journal of Advance Computational Engineering and Networking (IJACEN)*, volume 2, Issue 9, pp.6-11. [Link]
- [37] Nimeshkumar Patel, 2022." QUANTUM CRYPTOGRAPHY IN HEALTHCARE INFORMATION SYSTEMS: ENHANCING SECURITY IN MEDICAL DATA STORAGE AND COMMUNICATION", *Journal of Emerging Technologies and Innovative Research*, volume 9, issue 8, pp.g193-g202. [Link]
- [38] Bhat, A., & Gojanur, V. (2015). Evolution Of 4g: A Study. *International Journal of Innovative Research in Computer Science & Engineering (IJIRCSE)*. Booth, K. (2020, December 4). How 5G is breaking new ground in the construction industry. *BDC Magazine*.<https://bdcmagazine.com/2020/12/how-5g-is-breaking-new-ground-in-the-constructionindustry/>. [Link]
- [39] Nimeshkumar Patel, 2021." SUSTAINABLE SMART CITIES: LEVERAGING IOT AND DATA ANALYTICS FOR ENERGY EFFICIENCY AND URBAN DEVELOPMENT", *Journal of Emerging Technologies and Innovative Research*, volume 8, Issue 3, pp.313-319. [Link]

- [40] Bhat, A., Gojanur, V., & Hegde, R. (2014). 5G evolution and need: A study. In International conference on electrical, electronics, signals, communication and optimization (EESCO) – 2015.[Link]
- [41] A. Bhat, V. Gojanur, and R. Hegde. 2015. 4G protocol and architecture for BYOD over Cloud Computing. In Communications and Signal Processing (ICCSP), 2015 International Conference on. 0308-0313. Google Scholar. [Link]
- [42] Gokul Ramadoss , 2022." Care and Disease Management: Why Managed Care Organizations (MCOs) Need to have an Inclusive Approach to Patient Care", Progress in Medical Science, VOL 6, NO. 3, PAGE 1 – 5, [Link]
- [43] Gokul Ramadoss , 2022." EHR & EMR - A Wholesome View on its Impact in EDI Transaction", Progress in Medical Science, VOL 6, NO. 5, PAGE 1 – 4, [Link]
- [44] Radhika Kanubaddhi, "Real-Time Recommendation Engine: A Hybrid Approach Using Oracle RTD, Polynomial Regression, and Naive Bayes," SSRG International Journal of Computer Science and Engineering , vol. 8, no. 3, pp. 11-16, 2021. Crossref, <https://doi.org/10.14445/23488387/IJCSE-V8I3P103>
- [45] Radhika Kanubaddhi, 2022. "Designing an Enterprise-Grade, Cloud-Native Chatbot Solution for the Hospitality Industry Using Azure QnA Maker and Azure LUIS", ESP Journal of Engineering & Technology Advancements, 2(1): 56-62. <https://espjeta.org/jeta-v2i1p108>
- [46] Anusha Medavaka, 2024. "AWS AI from Financial Services Transforming Risk Management and Investment Strategies" ESP International Journal of Advancements in Computational Technology (ESP-IJACT) Volume 2, Issue 3: 116-129.
- [47] Muthukumaran Vaithianathan, Mahesh Patil, Shunyee Frank Ng, Shiv Udkar, 2024. "Verification of Low-Power Semiconductor Designs Using UVM", ESP Journal of Engineering & Technology Advancements 4(3): 28-44.
- [48] Lakshmana Kumar Yenduri, 2024. "Low Latency High Throughput Data Serving Layer for Generative AI Applications using the REST-based APIs" ESP International Journal of Advancements in Computational Technology (ESP-IJACT) Volume 2, Issue 3: 61-76.
- [49] Anusha Medavaka, 2023. "Building Intelligent Systems on AWS: From Data Lakes to AI-Powered Insights", ESP International Journal of Advancements in Computational Technology (ESP-IJACT) Volume 1, Issue 3: 68-80.